

# Commitment to 2<sup>nd</sup> gen biofuel development...

## U.S. CELLULOSIC ETHANOL PROJECTS UNDER DEVELOPMENT AND CONSTRUCTION

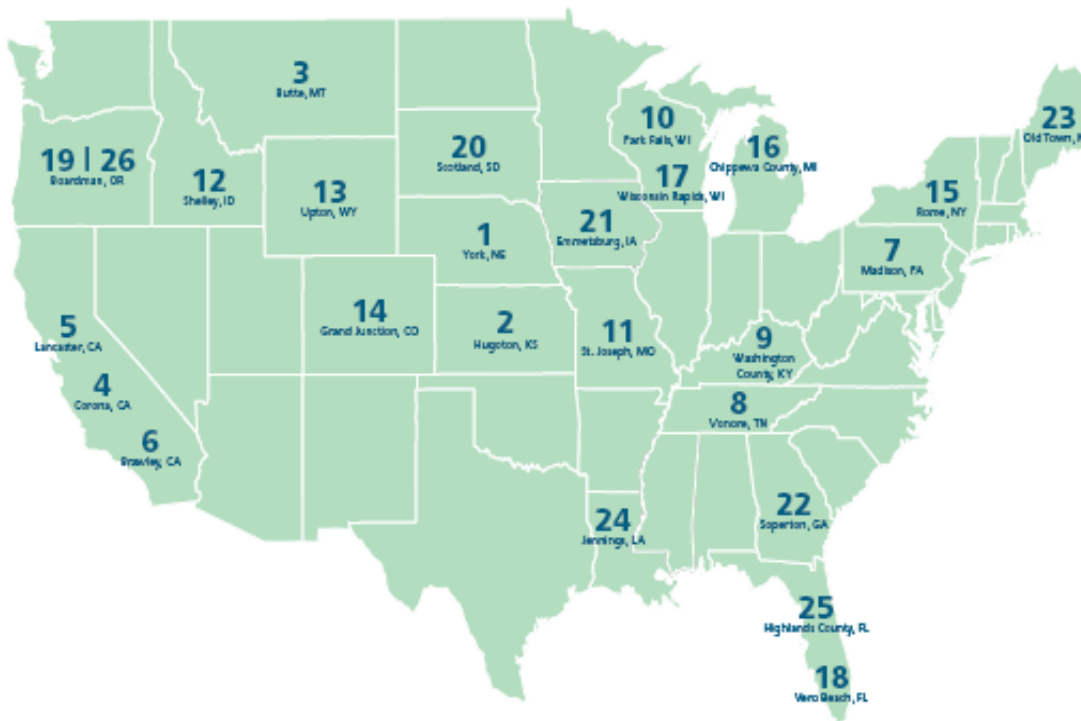

- 1. ABENGOA**  
Cornstover, wheat straw, milo stubble, switchgrass and other biomass.
- 2. ABENGOA**
- 3. AE BIOFUELS**  
Switchgrass, grass seed, grass straw and corn stalks.
- 4. BLUEFIRE**  
Green waste, wood waste, and other cellulosic urban wastes.
- 5. BLUEFIRE**
- 6. CALIFORNIA ETHANOL + POWER, LLC**  
Local Imperial Valley grown sugarcane facility powered by sugarcane bagasse.
- 7. COSKATA**  
Any carbon-based feedstock, including biomass, municipal solid waste, bagasse, and other agricultural waste.
- 8. DUPONT DANISCO CELLULOSIC ETHANOL LLC**  
Switchgrass, corn stover and corn cobs.
- 9. ECOFIN, LLC**  
Corn cobs.
- 10. FLAMBEAU RIVER BIOFUELS LLC**  
Softwood chips, wood, and forest residues.
- 11. ICM INC.**  
Switchgrass, forage, sorghum, stover.
- 12. IOGEN CORP.**  
Agricultural residues including wheat straw, barley straw, corn stover, switchgrass and rice straw.
- 13. KL PROCESS**  
Softwood, waste wood, including cardboard and paper.
- 14. LIGNOL INNOVATIONS**  
Woody biomass, agricultural residues, hardwood and softwood.
- 15. MASCOMA**  
Lignocellulosic biomass, including switchgrass, paper sludge, and wood chips.
- 16. MASCOMA**  
Consolidated bioprocessing refinery using bacteria to break down and ferment local wood chips.
- 17. NEWPAGE CORP.**  
Woody biomass, mill residues.
- 18. NEW PLANET ENERGY**  
Municipal solid waste (MSW); unrecyclable paper; construction & demolition debris; tree, yard and vegetative waste; and energy crops.
- 19. PACIFIC ETHANOL**  
Wheat straw, stover, and poplar residuals.
- 20. POET**  
Corn fiber, corn cobs and corn stalks.
- 21. POET**
- 22. RANGE FUELS INC.**  
Wood residues and wood-based energy crops, grasses and corn stover.
- 23. RSE PULP & CHEMICAL LLC**  
Woodchips (mixed hardwood).
- 24. VERENIUM**  
Sugarcane bagasse and specially bred energy cane.
- 25. VERENIUM**
- 26. ZEACHEM**  
Poplar trees, sugar, and wood chips.

## Infrastructure

- 2006 Roadmap
  - Increasing demand for biotechnology derived products
  - One of the main technology drivers of the 21<sup>st</sup> century
  - Australia heavily reliant on off-shore capability in these areas
  - Strategic investment in appropriate facilities would allow Australia to maximise the outcomes of R&D
- NCRIS capability 5.5 – Biotechnology Products
  - \$35 million - enhancing Australia's capacity to produce biotechnology products in pre-commercial quantities:
    - recombinant proteins, for use as potential therapeutics;
    - human cells, for transplantation or clinical activity involving human subjects;
    - biofuels.
- Biofuels process development and pilot production facilities

## Funding for the NCRIS biofuels sub-project

### Australian Government funding 2007 - 2011.

Total Federal funding	\$7,720,000
State government funding	\$6,200,000
Host institute cash contributions	\$200,000
Host institute in-kind funding	\$850,000
Contract services	\$1,071,000

Total investment - biofuels sub-project: \$16,041,000

### Expenditure

Capital	\$9,902,000	(61%)
Salary	\$3,009,000	(19%)
Consumables, subsidies, etc	\$3,130,000	(20%)



## NCRIS biofuels facilities

### Pilot scale manufacturing facilities



QUT biomass biorefinery pilot plant



SARDI microalgae photobioreactor facility

### Process development facilities



Macquarie University



University of NSW

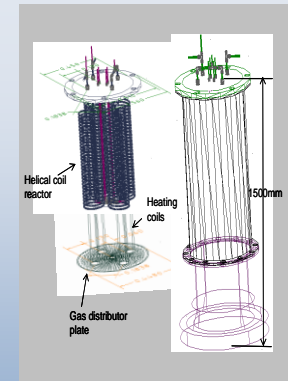

University of Sydney

## Facility access & pricing

Access to the facilities is available to meritorious researchers.

Class	Researcher type	Pricing Rate
<b>Tier 1</b>	Australian higher education institution or public sector research organisation.	Marginal Cost
<b>Tier 2</b>	<ul style="list-style-type: none"> <li>- Australian companies with less than 15 equivalent full-time employees;</li> <li>- Collaborations between a Tier 1 Researcher and one or more Tier 3 Researchers; and,</li> <li>- Australian companies owned wholly or in part by a Tier 1 Researcher.</li> </ul>	Intermediate Cost
<b>Tier 3</b>	International companies and all Australian companies not satisfying the criteria for a Tier 2 Researcher.	Commercial Rate (no discount)



## Mackay Renewable Biocommodities Pilot Plant



## Pilot scale development and demonstration



**Laboratory scale**

**Pilot scale**

**Commercial**

**\$0.1 m - \$1 m**

**\$1m - \$10 m**

**> \$100 m**

- Reduce the risk associated with new technology
  - Reduce investment risk
- Understand the process at a pre-commercial scale (lower cost)
- Produce product for market testing
- Provide data for commercial plant design



## Aim of the pilot plant

### Publicly available research infrastructure to:

- Develop new biofuel technologies
- Demonstrate technologies that are close to commercialisation
- Scale up process to ensure economic viability
- Produce quantities of product for product testing



### For the production of:

- Ethanol from cellulosic biomass
- Lignin products
- Other fermentation products

Operational from mid-2010.



## Pilot plant location – Racecourse Mill, Mackay, Queensland



- Site facilities include:
  - Hazardous goods storage
  - Waste treatment and disposal
  - PC2 fermentation capability

- Two full-time personnel funded by NCRIS to November 2012
- On-site office / laboratory with additional analytical and technical support available through QUT



## Andritz Inc steam-ex batch pretreatment reactor

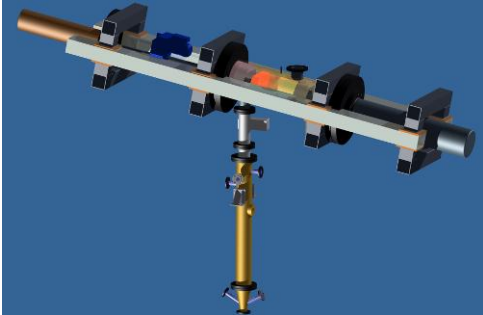

- Reactor designed and manufactured by Andritz Inc
- New reactor design with commercial application
- Designed for flexibility in application
  - Expensive materials of construction
  - Well instrumented
- Unique capability in Australia & globally
- Able to simulate most leading pretreatment technologies

## Other funded equipment



### Laboratory PDU's

- Mettler Toledo reaction calorimeter

- Hydrolysis reactors
- Fermentation equipment
- Bio-separation equipment
  - Centrifuge
  - Membrane filtration
- Distillation column
- Co-product recovery
- Tanks and pumps

## Commercial investment...



Abengoa Bioethanol facility

<http://www.thecosite.com/pictures3.html>

- The right partners
- Supportive environment for first plants
- Reduce the commercial risk
  - Technology choices
  - Feedstock selection (price and reliability)
  - Product price (ethanol, co-products, credits)

## Acknowledgements

- Prof James Dale
  - Dr Les Edge
  - Dr Bill Doherty
  
  - The Biorefinery Project team
  
  - The Syngenta Centre for Sugarcane Biofuels Development team
  
  - The Pilot Plant team
- Syngenta
  - Mackay Sugar Ltd
  - Queensland Government
  - Australian Government
  - Viridian Chemicals
  - Sugar Research Ltd
  - Hexion
  - CRC for Sugar Industry Innovation through Biotechnology



Further information on the NCRIS facilities:

[www.ncrisbiofuels.org](http://www.ncrisbiofuels.org)